

PARTS LIST
PACER PB - DRY VACUUM

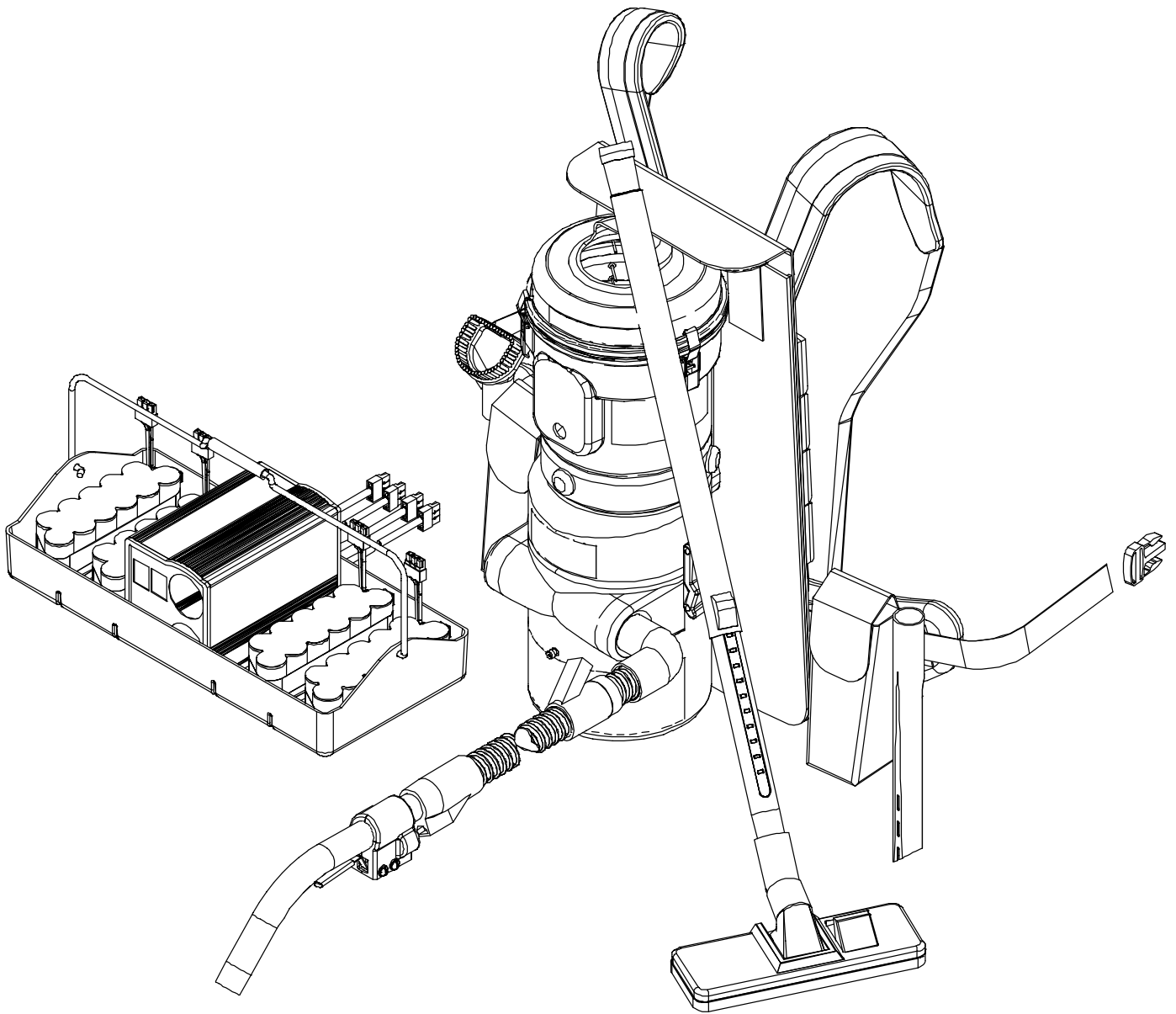

UPPER HOUSING ASSEMBLY

ITEM	PART NO.	DESCRIPTION	QTY
	6990839	CAP ASSEMBLY - INCLUDES:	1
101	6990831	REPLACEMENT CAP	1
101A	6990391	WARNING LABEL KIT	1
101B	6990991	LATCH	3
101C	9120319	5/32 X 3/8 DIAMETER HEAD POP RIVET - STEEL - PACK OF 5	3
101D	6990261	HEPA FILTER GASKET	1
101E	6990251	FILTER CAP GASKET'	1
102	6990381	EXHAUST FILTER - FOAM	1
103	6990241	FILTER SUPPORT	1
	6990849	TOP ASSEMBLY - INCLUDES:	1
104	6990841	TOP	1
104A	9120319	5/32 X 3/8 DIAMETER HEAD POP RIVET - STEEL - PACK OF 5	6
104B	6990991	LATCH	3
104C	6990391	WARNING LABEL KIT	1
104D	6990811	FOAM TAPE	24"
104E	6990291	SNAP RIVET	2
104F	6990391	WARNING LABEL KIT	1
104G	6990281	CIRCUIT BOARD SUPPORT	2
104H	6990431	WIRING DIAGRAM DECAL	1
105	6990441	PIGTAIL CORD - HOSE TO BOARD WITH STRAIN RELIEF	1
106	9120205	#8 X 1/2 PAN HEAD PHILLIPS SHEET METAL SCREW - PACK OF 3	1
107	6991011	FINISHING CAP WASHER	3
108	9121030	1/4-20 X 1 1/4 FLAT HEAD PHILLIPS SCREW - PACK OF 5	3
109	6991001	PLASTIC SCREW CAP	3
110	6990591	CABLE - BATTERY TO BOARD WITH STRAIN RELIEF	1
111	6990151	CIRCUIT BOARD	1
112	6991131	HEPA FILTER - OPTIONAL	1

UPPER HOUSING ASSEMBLY

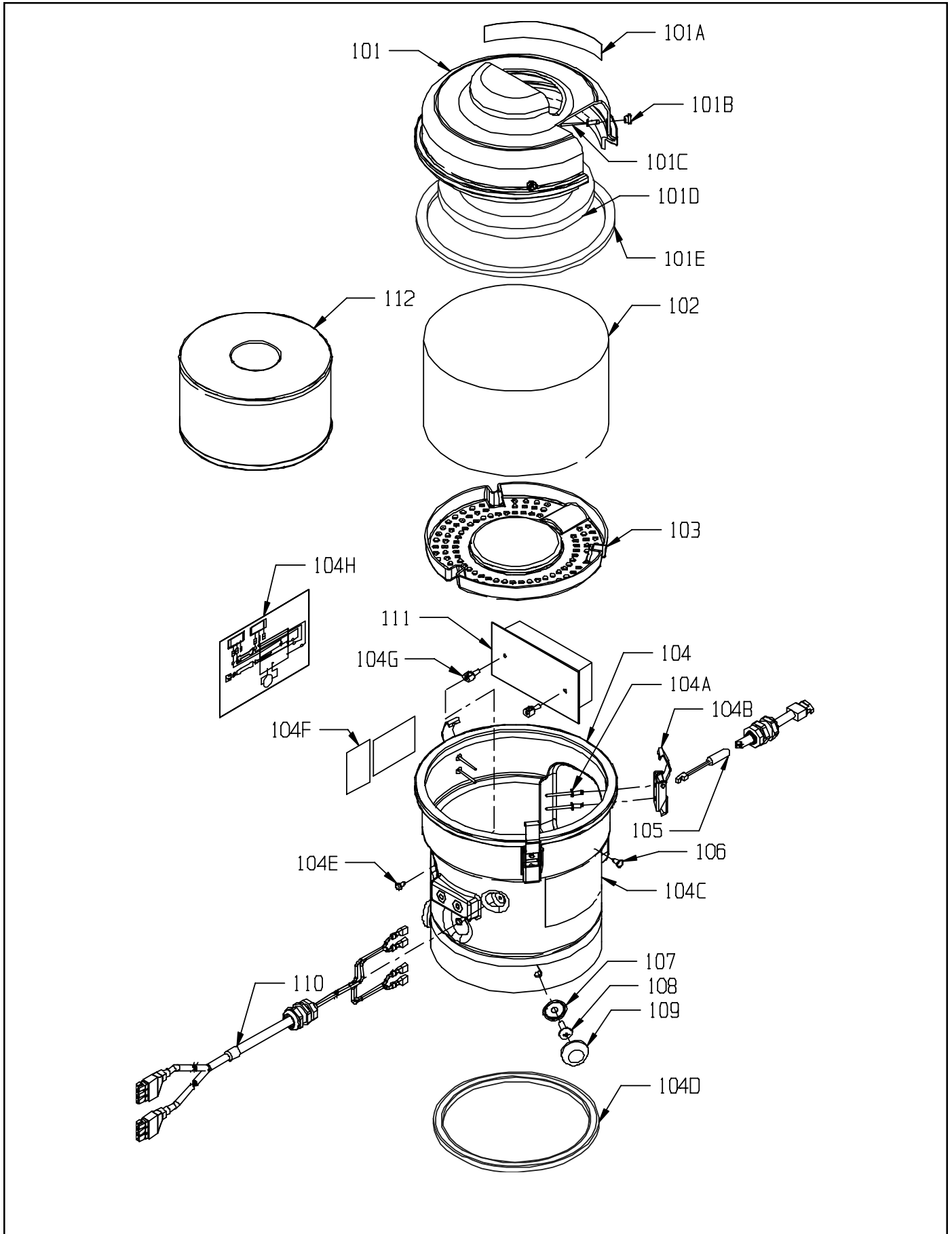

LOWER HOUSING ASSEMBLY

ITEM	PART NO.	DESCRIPTION	QTY
201	6990951	VAC MOTOR CAP	1
202	9120610	10-24 X 5/8 PAN HEAD PHILLIPS THREAD CUTTING SCREW - PACK OF 10	4
203	6990121	VACUUM MOTOR MOUNTING PLATE	1
204	6990961	INSULATED FEMALE TERMINAL	2
205	6990171	VACUUM MOTOR	1
206	6990131	MOTOR GASKET	1
	6990859	HOUSING ASSEMBLY - INCLUDES:	1
207	6990851	HOUSING	1
207A	6990421	NAMING LABEL	1
207B	9120319	5/32 X 3/8 DIAMETER HEAD POP RIVET - STEEL - PACK OF 5	4
207C	6990971	SOFT DRAW LATCH WITH KEEPER - KEEPER SHOWN	2
208	6990981	WELL NUT	3
	6990669	FILTER AND GASKET KIT - INCLUDES:	1
209	----	FILTER	1
209A	6991091	CANISTER TO FILTER GASKET	1
	6990869	CANISTER ASSEMBLY - INCLUDES:	1
210	6990861	CANISTER	1
210A	9120319	5/32 X 3/8 DIAMETER HEAD POP RIVET - STEEL - PACK OF 5	4
210B	6990971	SOFT DRAW LATCH WITH KEEPER - LATCH SHOWN	2
211	9121289	1/4 X 3/16 (10-24) SOCKET HEAD SHOULDER BOLT - PACK OF 1	1
212	9120890	1/4-20 THIN HEX NUT WITH NY-LOK INSERT - PACK OF 5	1
213	9120930	9/32 I.D. X 5/8 O.D. FLAT WASHER (1/4) - PACK OF 10	1
214	6990571	TAPERED PLUG	1
215	6990641	LANYARD	1
216	9121130	1/4-20 X 1 1/2 TRUSS HEAD PHILLIPS MACHINE SCREW - PACK OF 5	1
217	6991121	FRONT DECAL 3" X 12"	1
	6991119	FILTER CUP AND GASKET KIT - INCLUDES	1
218	6991071	CUP - FILTER	1
209A	6991091	CANISTER TO FILTER GASKET	1

LOWER HOUSING ASSEMBLY

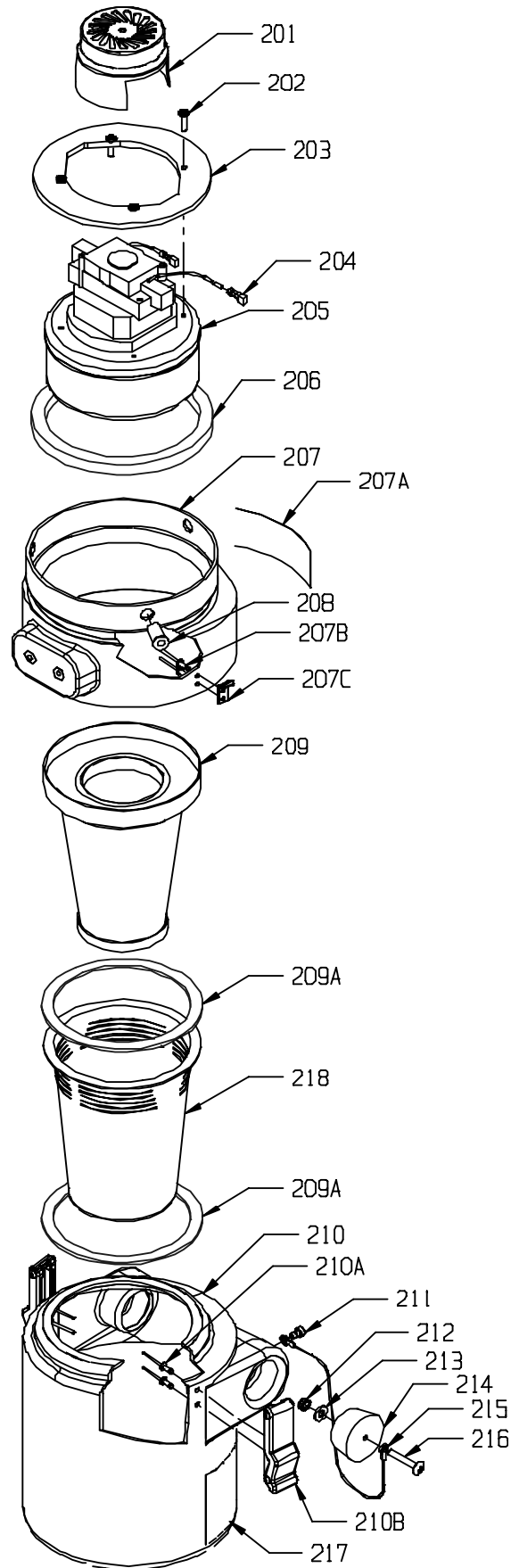

TRIGGER AND HOSE ASSEMBLY

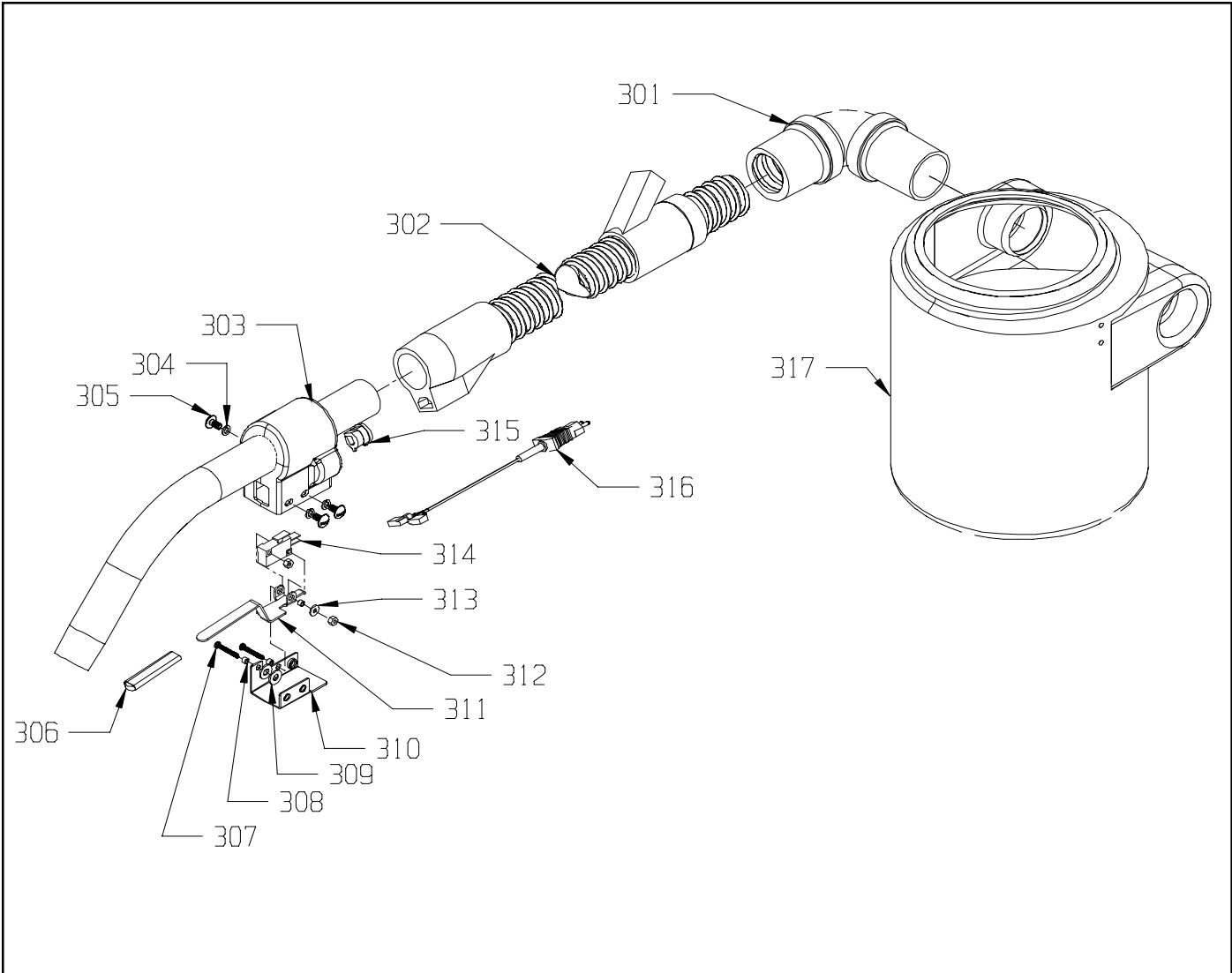

<u>ITEM</u>	<u>PART NO.</u>	<u>DESCRIPTION</u>	<u>QTY</u>
301	6990751	CUFF - 90° 1 1/2 X 1 1/4	1
302	6990091	ELECTRIC HOSE - 1 1/4" I.D. - INCLUDES CUFF AT TRIGGER END	1
303	6990011	TRIGGER HOUSING	1
304	9120320	#10 SPLIT LOCK WASHER	3
305	9120500	10-24 X 3/8 TRUSS HEAD PHILLIPS MACHINE SCREW - PACK OF 10	3
306	6990341	TRIGGER COVER	1
307	9120014	4-40 X 7/8 PAN HEAD PHILLIPS SCREW - PACK OF 10	2
308	6990071	#4 I.D. X 3/16 O.D. X 1/8 SPACER	3
309	9120370	7/32 I.D. X 1/2 O.D. FLAT WASHER (#10) - PACK OF 10	2
310	6990031	TRIGGER AND SWITCH MOUNT BRACKET	1
311	6990021	TRIGGER	1
312	9120015	4-40 HEX NUT WITH STAR LOCK WASHER - PACK OF 10	2
313	9120016	#4 FLAT WASHER - PACK OF 10	1
314	6990041	10 AMP MOMENTARY SWITCH	1
315	6990081	DOUBLE "D" STRAIN RELIEF	1
316	6990311	PIGTAIL - HOSE TO TRIGGER	1
317	6990869	CANISTER ASSEMBLY	1

BACK PACK HARNESS, BATTERIES & TOOLS

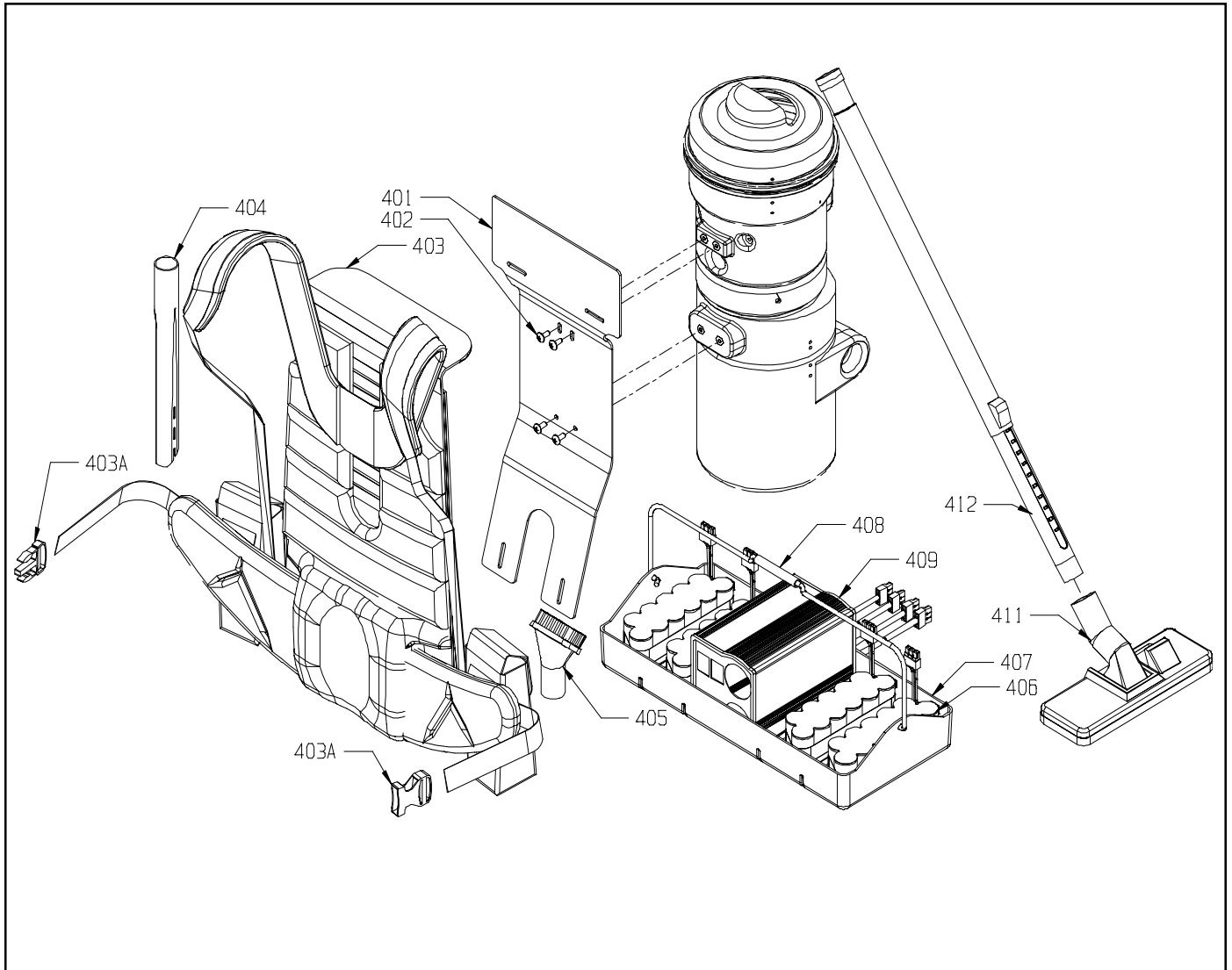

<u>ITEM</u>	<u>PART NO.</u>	<u>DESCRIPTION</u>	<u>QTY</u>
401	6990581	BACK PACK ATTACHMENT PLATE	1
402	9121000	1/4-20 X 5/8 TRUSS HEAD PHILLIPS MACHINE SCREW - PACK OF 5	4
403	6990621	BACKPACK HARNESS - INCLUDES:	1
403A	6990911	BUCKLE - 1 1/2"	1
404	6990491	CREVICE TOOL	1
405	6990541	ROUND BRUSH TOOL	1
406	6990501	BATTERY - NI-MH 9.5 AH "D" SIZE 13.2V - 2 BATTERIES NEEDED FOR OPERATION	4
	6991179	BATTERY AND CHARGER TRAY ASSEMBLY - INCLUDES:	1
407	6990521	BATTERY TRAY	1
408	6990561	BATTERY TRAY HANDLE	1
409	6990511	BATTERY CHARGER - CHARGES UP TO 4 BATTERIES - INCLUDES:	1
409A	6991141	CORD - 120 VAC - NOT SHOWN	1
410	6991151	CORD - 240 VAC - NOT SHOWN	1
411	6990471	COMBINATION FLOOR TOOL - 1 1/4	1
412	6990461	RETRACTABLE ALUMINUM WAND - 1 1/4	1

WIRE DIAGRAM - VACUUM ONLY

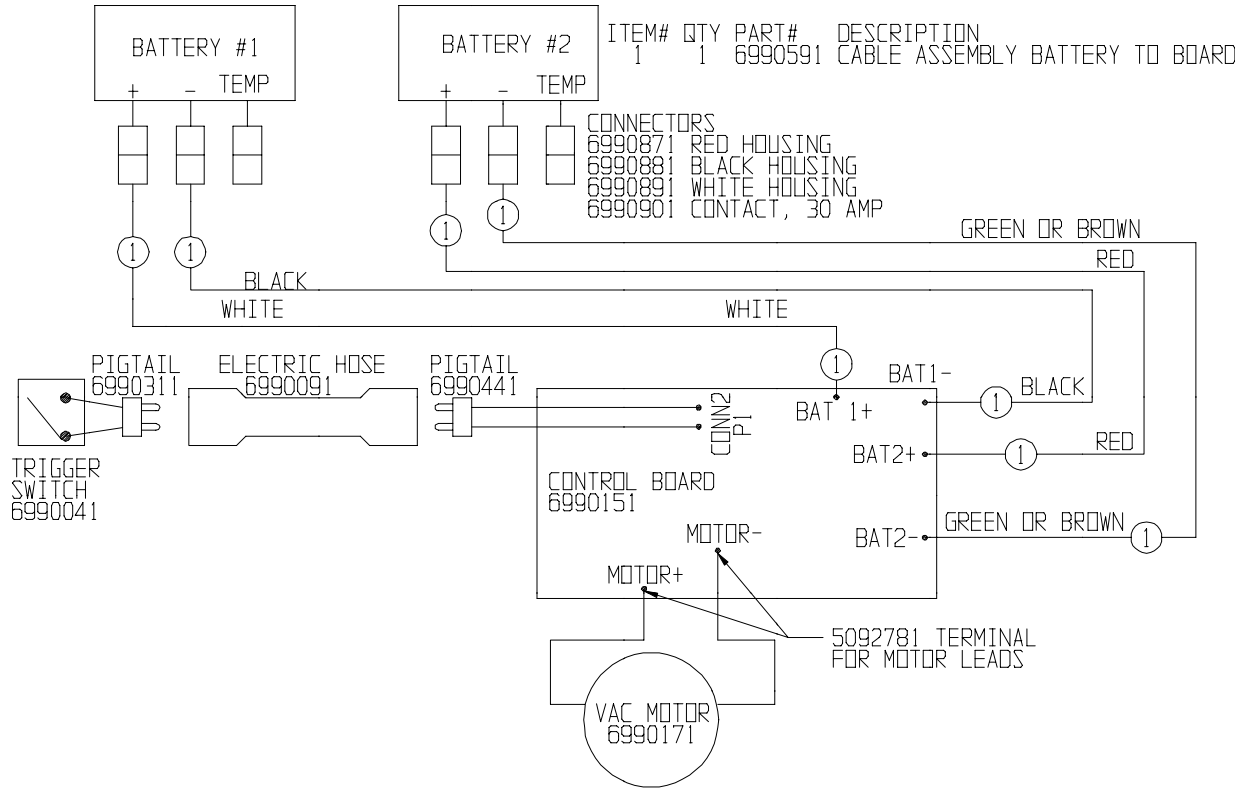

ACCESSORIES



ITEM	PART NO.	DESCRIPTION	QTY
501	6990791	TRASH CAN ACCESSORY SKIRT	1
502	6990781	TRASH CAN MOUNT HANGER	2
503	6990801	PACER PB HOSE, 1 1/4 I.D. X 10'	1

Trash can not available from NSS. Contact your local JanSan Distributor



NSS ® Enterprises, Inc.

3115 Frenchmens Road, Toledo, Ohio 43607
 PHONE (419) 531-2121 FAX (419) 531-3761
NSS ® Enterprises, Inc. European Distribution Centre
 Unit II, Pinfold Trading Estate * 55 Nottingham Road
 STAPLEFORD, NOTTINGHAM NG9 8AD ENGLAND U.K.
 PHONE: (44) 0115 939 1568 * FAX: (44) 0115 949 0615